

CONFORMATION STUDIES ON AND ASSESSMENT BY SPECTRAL ANALYSIS
OF THE PROTEIN-CHROMOPHORE INTERACTION
OF THE MACROMOLECULAR ANTITUMOR
ANTIBIOTIC C-1027

TOSHIO OTANI

Anticancer & Antimicrobial Research Laboratory, Taiho Pharmaceutical Co. Ltd.,
Kawauchi-cho, Tokushima 771-01, Japan

(Received for publication December 21, 1992)

Characterization of the secondary structure of the antitumor antibiotic C-1027 has been made from a comparison of C-1027 and its apoprotein by various analytical means. The results indicated the antibiotic to be abundant in β -structure by measurements of Fourier-transform infrared (FT-IR) spectroscopy and the circular dichroism (CD) spectrum, and by a prediction of the secondary structure based on the amino acid sequence of the peptide. In comparison of the IR spectra of their proteins in D_2O , the apoprotein exhibited a faster H-D exchange than C-1027, indicating an increase in the "non-motile parts" of the β -sheets formed through the protein-chromophore interaction in holo-C-1027. The prediction of hydrophobic index indicated the hydrophobic residues of the apoprotein to be predominantly located in the β -sheet structures, suggesting hydrophobic interaction in the binding between chromophore and apoprotein. Further, the interaction between chromophore and apoprotein was detected by a fluorescence method. The result showed the dissociation constant (K_d) to be $6.88 \times 10^{-5} M$, indicating that the chromophore is tightly bound to the protein moiety.

The antitumor antibiotic C-1027 and its apoprotein, C-1027-AG, were isolated at the same time from a culture filtrate of *Streptomyces globisporus* C-1027. This antibiotic has been extensively characterized during recent years, and has been shown to be composed of an apoprotein and an associated non-protein chromophore^{1,2)}. The apoprotein is an acidic single-chain polypeptide composed of 110 amino acid residues, M.W. ca. 10,500, whose primary structure has been recently elucidated on the basis of the Edman degradation procedure using fragment peptides obtained by enzyme hydrolysis³⁾, and also from cloning and nucleotide sequencing of the apoprotein gene.⁴⁾ The sequence was determined as shown in Fig. 1. It notably lacks methionine and tryptophan residues in its composition and contains 2 intramolecular disulfide bonds, one between cys(36) and cys(45), and the other between cys(86) and cys(91). On the other hand, although the total chemical structure of the non-protein chromophore has not yet been elucidated because of exceptional instability, the chromophore extracted with ethyl acetate under alkaline conditions has been characterized, and the structure of one of its degradation products, component II-F₃, has been reported to be 3,4-dihydro-7-methoxy-2-methylene-3-oxo-2H-1,4-benzoxazine-5-carboxylic

Fig. 1. Amino acid sequence of C-1027 apoprotein.

```

1             10             20
Ala-Pro-Ala-Phe-Ser-Val-Ser-Pro-Ala-Ser-Gly-Leu-Ser-Asp-Gly-Gln-Ser-Val-Ser-Val-Ser-Val-Ser-Gly-Ala-
                30             40
Ala-Ala-Gly-Glu-Thr-Tyr-Tyr-Ile-Ala-Gln-Cys-Ala-Pro-Val-Gly-Gly-Gln-Asp-Ala-Cys-Asn-Pro-Ala-Thr-
50             60             70
Ala-Thr-Ser-Phe-Thr-Thr-Asp-Ala-Ser-Gly-Ala-Ala-Ser-Phe-Ser-Phe-Val-Val-Arg-Lys-Ser-Tyr-Thr-Gly-
80             90
Ser-Thr-Pro-Glu-Gly-Thr-Pro-Val-Gly-Ser-Val-Asp-Cys-Ala-Thr-Ala-Ala-Cys-Asn-Leu-Gly-Ala-Gly-Asn-
100            110
Ser-Gly-Leu-Asp-Leu-Gly-His-Val-Ala-Leu-Thr-Phe-Gly

```

acid⁵) (Fig. 2). Several biological properties of C-1027 have been described, such as growth inhibition of Gram-positive bacteria, of some strains of Gram-negative bacteria, and of a number of transplantable solid tumors and leukemias in mice⁶. It has been shown that L-1210 cells grown in tissue culture in the presence of C-1027 undergo a preferential inhibition of DNA synthesis and that C-1027 treatment results in cleavage of cellular DNA *in vitro* and *in vivo*^{7,8}. All the biological activity of C-1027 was reported to be associated with the non-protein chromophore that was extractable by organic solvents, while the apoprotein, C-1027-AG, did not show any antimicrobial and antitumor activities. Furthermore, we found that antibiotic C-1027 (holo-antibiotic) had some aminopeptidase activity but that neither its chromophore nor its apoprotein alone had any activity and that the cytotoxicity *in vitro* was diminished by amastatin, an inhibitor of aminopeptidase⁹.

C-1027 is one of a large group of protein antibiotics isolated from different strains of *Streptomyces*, and members of the group include neocarzinostatin (NCS)¹⁰, auromomycin (AUR)¹¹, macromomycin (MCR)¹², largomycin (LRG)¹³, and actinoxanthin (AXN)¹⁴. NCS and other members of this family of antitumor agents are similar in size, and share amino acid sequence homology with C-1027. However, these antibiotics may be presumed to differ in the secondary and three-dimensional structure of the apoprotein and in the structure of this chromophore. In the present communication, we will discuss side chain conformations based on circular dichroism (CD) data, and peptide backbone conformation (secondary structure) based on infrared (IR) spectroscopy for C-1027 and its apoprotein to understand the features of the C-1027 non-protein chromophore environment. Further, the mode of binding between the apoprotein and non-protein chromophore is described based on the determination of fluorescence emission. We also make a prediction of the secondary structure and assign the hydrophobic index of C-1027 by using a computer program developed for this purpose, and compare our results with those on other protein antibiotics.

Materials and Methods

Chemicals

Large-scale production of antibiotic C-1027 and its apoprotein (C-1027-AG) was achieved by a purification procedure, employing DEAE-cellulofine, Butyl-cellulofine, and Cellulofine GCL-90 (Seikagaku Kogyo Co., Ltd.), that represents an improvement over the previously described process³. The purified C-1027 exhibited an absorption maximum at 275 nm and a broad shoulder between 340 and 360 nm. In the spectrum of the apoprotein, the 275-nm peak was observed, but the broad shoulder was absent. C-1027-UV was prepared by lyophilization after irradiation with UV-light for 1 hour, as reported in our previous paper². The hydrochloride salt of chromophore component II (chr-II) was obtained by preparative high-pressure liquid chromatography (HPLC) on a TSKgel ODS-120A column (30 × 10.8 cm, i.d., Tosoh Co., Ltd.), with acetonitrile-0.01 N HCl (25:75) as eluant, of an ethyl acetate extract of the crude protein as described previously⁵. In all steps, care was taken to reduce the exposure of the drug to light. All the other chemicals used were of the highest grade commercially available.

Spectral Studies

The CD spectra were measured under identical experimental conditions under a constant nitrogen flush with a JASCO J-500A spectropolarimeter equipped with a data processor. CD spectra were recorded

Fig. 2. Structure of degradation product of C-1027 chromophore.

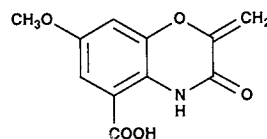

in the wavelength region of 200~450 nm in 1/15 M phosphate buffer (pH 7.0) for C-1027 and apoprotein and in MeOH solution for chr-II. The observations were expressed in terms of $\Delta\epsilon$ in $\text{cm}^{-1}\cdot\text{mol}^{-1}$.

Fourier-transform infrared (FT-IR) measurements were performed at room temperature with a JEOL JIR-100 spectrometer. The respective spectra of C-1027, its apoprotein, and C-1027-UV (1.5 mg/200 μl) were measured at 4 cm^{-1} resolution from 1300 to 1800 cm^{-1} in deuterium oxide (D_2O) solution, and signals of D_2O . The deconvolved spectra for the prediction of secondary structure were resolved in Gaussian components from 1600 to 1700 cm^{-1} at 5 minutes after addition of D_2O by the curve-fitting analysis of a computer program that utilizes Gaussian-Newton interaction.

Fluorescence studies were performed on a Hitachi 650-40 spectrofluorometer. C-1027 and its apoprotein were usually analyzed at a concentration of 0.5 mg/ml in 0.01 M Tris-HCl buffer solution (pH 7.9). Emission spectra were recorded at excitation wavelengths of 280 and 350 nm. Spectra were taken at 10°C -intervals ranging from 30 to 80°C with the temperature controlled by a thermoregulator. To test the interaction between apoprotein and non-protein chromophore, we prepared C-1027 chr-II (from 0.8 to $5 \times 10^{-5}\text{ M}$) and apoprotein ($5 \times 10^{-5}\text{ M}$) solutions in the same buffer. Kinetic measurements of fluorescence change were conducted by adding buffer solution containing apoprotein to chr-II in aqueous buffer solutions, and changes in the 426-nm fluorescence of chr-II excited at 350 nm were observed. Kinetic constant was determined from the linear correlation between $1/\Delta F$ and $1/(C)$ according to the method of KONDO *et al.*¹⁵⁾.

Results and Discussion

Fig. 3 shows CD spectra of C-1027 and apoprotein in 1/15 M phosphate buffer (pH 7.0) in comparison with that of C-1027 chr-II. Their CD spectra were essentially identical in the region of the peptide absorbance (210~245 nm), but differed at the longer wavelengths. C-1027 showed a negative peak centered around 300 and 350 nm attributed to the non-protein chromophore that was absent in the apoprotein. Both proteins, having two disulfide bonds, contain the following chromophores, which might contribute to the

Fig. 3. CD spectra of C-1027, apoprotein, and chromophore component II.

— C-1027, --- apoprotein, - - - chromophore component II.

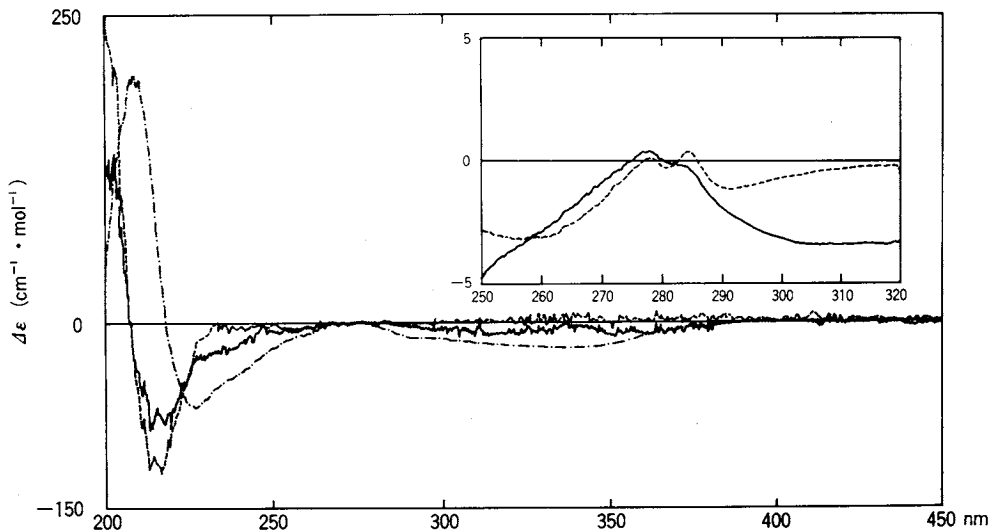

The respective spectra from 200 to 450 nm were taken of a 0.2 mg/ml solution in a cell of 1-mm path length. The spectra from 250 to 320 nm (inset) were of a 1.0 mg/ml solution in a cell of 10-mm path length.

Fig. 4. Changes in CD spectra of antibiotic C-1027 (a) and apoprotein (b).

The first spectrum was obtained at 30°C —, followed by spectra at 40°C ---, 50°C —, 60°C —, 70°C —, 80°C — and 90°C —.

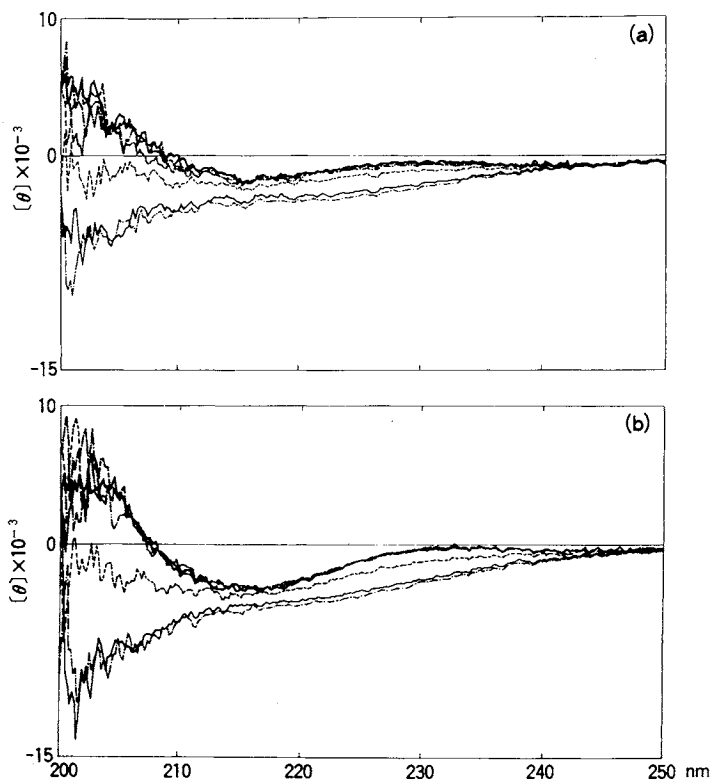

C-1027 and apoprotein (0.4 mg/ml) in 1/15 M phosphate buffer (pH 7.0) were heated by 10°C increments to 90°C.

CD measurement: three tyrosines and five phenylalanines. The positive extremum at 203 nm and the negative one at 219 nm, indicative of a large percentage of β -pleated sheet structure, are consistent with a tightly folded native configuration, though the ellipticities shown were lower than those of the β -pleated sheet. Several attempts have been made to predict protein conformation from amino acid sequence and amino acid composition by use of proteins of known conformation. Using parameters published by YANG *et al.*¹⁶⁾, we attempted to calculate the contributions of α -helical, β -pleated, and randomly coiled segments toward the conformation of C-1027 and its apoprotein. The respective structure contents calculated as compared with those of ordinary proteins such as globulin were as follows: α -helix, -2%, -7%; β -sheet, 39%, 59%; β -turn, 5%, -12%; random coil, 59%, 60%. As CD is a very useful method for detecting conformational changes in proteins, we examined the effect of temperature on the secondary structure of C-1027 and of its apoprotein by measuring their CD spectra. As shown in Fig. 4, the positive band at around 203 nm was transformed with increasing temperature to a negative band at the boundary ranging near 70°C, while the negative band at around 216 nm was scarcely influenced in either protein. These spectral changes of both proteins suggest that the content of β -sheet structure decreased. However, the usefulness of these data for obtaining specific information about the peptide backbone remains uncertain.

Fig. 5. Changes in IR spectra of C-1027, apoprotein, and C-1027-UV in amide I and II regions after D₂O addition.

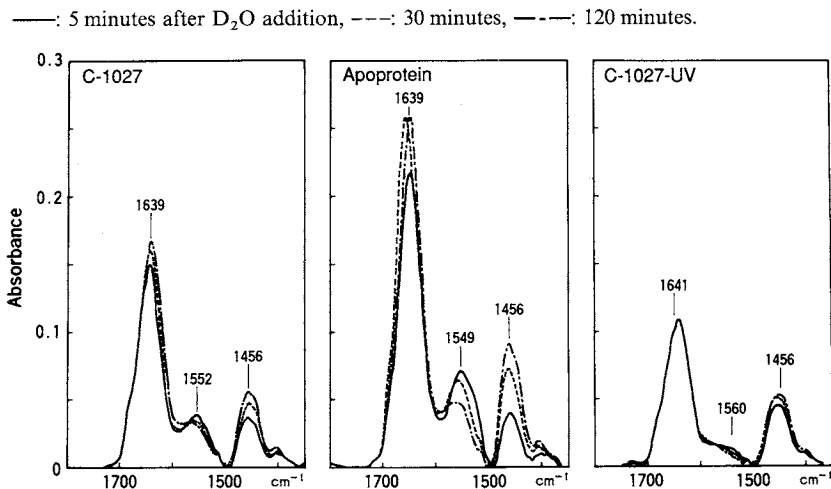

C-1027-UV: C-1027 was irradiated with UV-light for 1 hour from a distance of 25 cm.

Fig. 6. FT-IR spectra of C-1027 (a) and apoprotein (b) and resolution into Gaussian bands.

— Amide I band found, --- Gaussian bands.

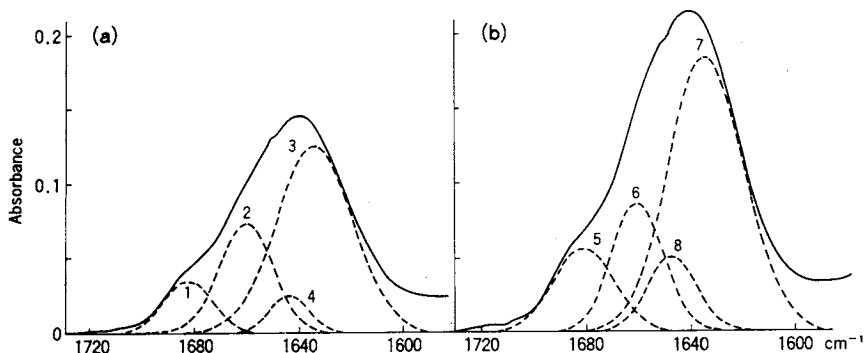

The symbols 1 and 5, 2 and 6, 3 and 7, and 4 and 8 indicate β -turn, α -helix, β -sheet and other, respectively.

Band assignments in IR spectroscopy are primarily based on the mode of vibrations attributed to C=O stretching (amide I, 1650 cm^{-1} region) and NH deformation (amide II, 1530 cm^{-1} region), thus avoiding the perturbation caused by other side chain chromophores that usually have small and different absorption bands of predictable area. C-1027 and its apoprotein showed similar IR spectra in amide I and II regions in D₂O solution (Fig. 5). The spectral characteristics obtained here, as a strong absorption for amide I around 1639 cm^{-1} and a weaker one close to 1684 cm^{-1} , and as an intense amide II frequency at 1552 cm^{-1} , are similar to those in the literature for antiparallel β -pleated sheet proteins¹⁷). The absorption at 1651 cm^{-1} indicates α -helix conformation. The amide II absorption around 1552 cm^{-1} occurred at a longer wavelength in comparison with that of NCS^{18,19}), MCR, AUR²⁰) and their apoproteins. We resolved the IR spectra of the amide I region corresponding to each of the four secondary structures based on the method reported by SARVER²¹). Fig. 6 shows the calculated amide I region at the peak

Table 1. Analysis of secondary structures by individual component bands of amide I band with C-1027 and apoprotein.

	Peak No. ^a	Wave-length (cm ⁻¹)	Absorbance ^b	% ^c
C-1027	1	1682	0.036	14
	2	1660	0.074	28
	3	1634	0.125	48
	4	1644	0.026	10
Apoprotein	5	1681	0.056	15
	6	1660	0.086	23
	7	1633	0.184	49
	8	1647	0.050	13

^a Peak numbers were correlated with respective secondary structures, as shown in Fig. 6.

^b Absorbance as integrated intensities.

^c Percent of total absorbance.

positions of 1682, 1660, 1644, and 1634 cm⁻¹ for the β -turn, α -helix, others, and β -sheet conformation, respectively. The positions of these bands are

given in Table 1 along with their absorption intensities, which are related to the population of the corresponding secondary structure. The results suggest the presence of approximately 50% β -structure in both C-1027 and its apoprotein. This result is compatible with the amino acid compositions of both proteins. These proteins have many threonine (10 residues/110 residue), valine (10/110), glycine (15/110), and proline (6/110) residues, which make up approximately 40% of the total amino acids, and they preferentially compose the β -sheet as shown in NCS, AUR, and MCR. Glycine (15/110), which destabilizes α -helix structure²²), is present as the most abundant amino acid in this protein.

After addition of D₂O to lyophilized C-1027, apoprotein, and C-1027-UV, the decrease in the ratio of amide II to amide I absorbance in the proportion of H-D exchange was faster in the apoprotein than in C-1027 (Fig. 7). H-D exchange velocity in the NH-CO of apoprotein is greater than that in C-1027. These results show holo-C-1027 and apoprotein to be similar in IR spectra in a static configuration, but different in the H-D exchange, thus reflecting a dynamic configuration freedom denoted by "motility", as was also noted in AUR and MCR²⁰). This difference among these proteins is relative to the difference in their chromophore. Therefore, these data presumably indicate the existence of "non-motile parts" of the β -sheet formed through the apoprotein-chromophore interaction in C-1027. On the other hand, the H-D exchange of UV-irradiated C-1027 was similar to that of holo-C-1027. We reported previously that the enzymatic and antitumor activities of the holo-antibiotic were readily lost upon UV-irradiation, indicating that the intact structure of the chromophore was needed to maintain the native conformation of the holo-antibiotic⁹). Thus, the conformation of the apoprotein may be very important for binding of the C-1027 chromophore. Such properties of the apoprotein should be important in connection with stability of the C-1027 chromophore and its biological activities.

Based on the complete amino acid sequence determined in the previous study^{3,4}), we attempted by the method of CHOU and FASMAN²²) to predict the secondary structure of this protein using computer program developed for this purpose. As shown in Fig. 8, we propose two helical segments, five β -sheet regions, and

Fig. 7. Time course of H-D exchange in C-1027, apoprotein, and C-1027-UV.

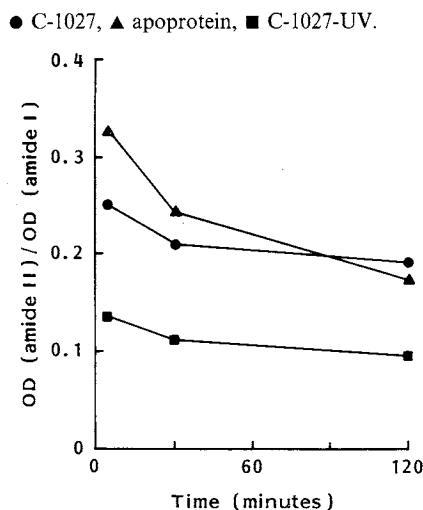

C-1027-UV: C-1027 was irradiated with UV-light for 1 hour from a distance of 25 cm.

Fig. 8. Prediction of secondary structure of C-1027 apoprotein.

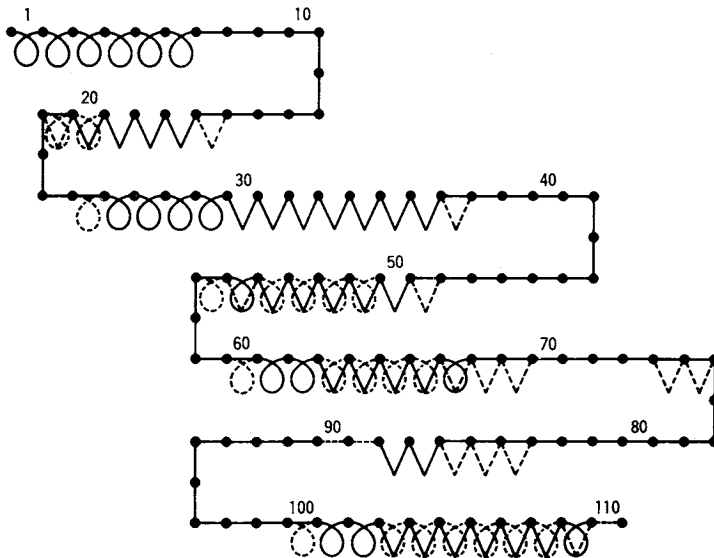
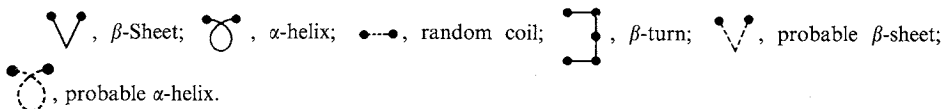

The prediction was made by the method of CHOU and FASMAN²²⁾, using a computer program.

six β -turns. The coil form was assigned to the remaining segments. The fraction of the total residues represented by each form was 15% by helices, 26% by β -sheets, 56% by β -turns, and 3% by random coils. However, α -helix and β -turn regions at 16~17, 21~22, 37~38, 49~50, 55~56, 67~70, 74~76, 84~87, and 108~109 may possibly exist as β -sheet. If true, the percentage of each form among the total residues would be 13% for α -helices, 38% for β -sheets, 46% for β -turns, and 3% for random coils. This result resembles closely that obtained by CD or IR analysis. These findings suggest that C-1027 and its apoprotein are rather poor in α -helix type structure. This result is in agreement with the fact that the amino acid composition is more in favor of a "non-helix" type structure. These observations indicate that C-1027 possesses a very tightly folded conformation, which probably is due to the considerable content of β -pleated sheet structure.

Hydrophilic-hydrophobic properties of C-1027 apoprotein were examined by means of the hydrophatic index plot of KYTE and DOOLITTLE²³⁾. As shown in Fig. 9 with the single-letter designation of amino acid sequence, there are mainly five hydrophobic regions in the apoprotein, located in positions 17~22, 32~36, 60~64, 79~86, and 100~107. Hydrophobic residues of the apoprotein are predominantly located in the β -sheet structure. In the case of NCS the highly hydrophobic clusters in the apoprotein are necessary for binding of the latter to its chromophore²⁴⁾. Likewise, these five hydrophobic clusters in the apoprotein of C-1027 may play an important role in the hydrophobic interaction with the hydrophobic part of its non-protein chromophore. In practice, separation of the apoprotein from C-1027 may be achieved by taking advantage of the difference in hydrophobicity by the purification of C-1027 on Butylcellulofine.

Fluorescence spectra of C-1027 and its apoprotein in 0.01 M Tris-HCl buffer (pH 7.9) were as shown in Fig. 10 with the fluorescence excitation spectrum monitored at 280 and 350 nm. The fluorescence emission

Fig. 9. Plot of hydropathic index of C-1027. (1) Hydrophobic amino acid; (2) hydrophilic amino acid.

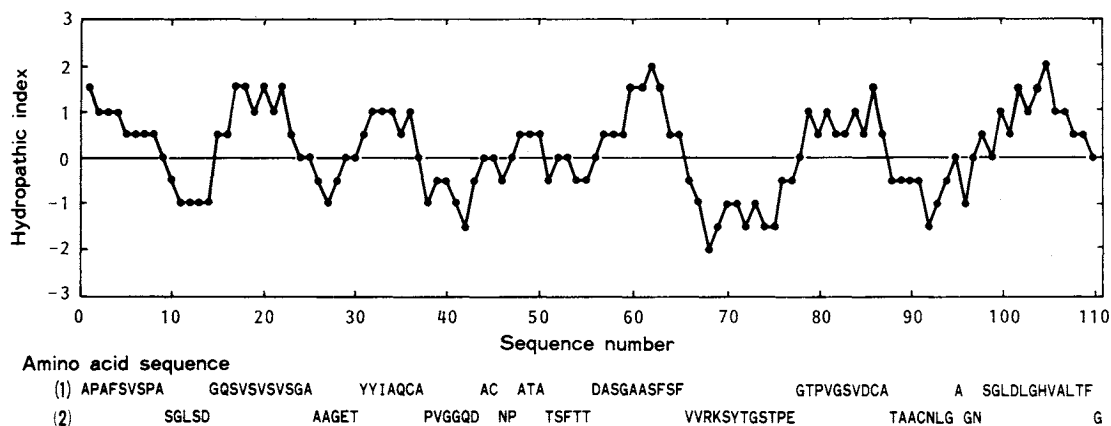

The hydropathic indices were calculated over every 9 residues by the method of KYTE and DOOLITTLE²³.

Fig. 10. Thermal denaturation fluorescence emission spectra of C-1027 apoprotein (a) and C-1027 (b).

The first spectrum was obtained at 30°C —, followed by spectra at 40°C ---, 50°C — —, 60°C — — —, 70°C — — — —, and 80°C — — — —. Left panels, excitation at 280 nm; right panels, excitation at 350 nm.

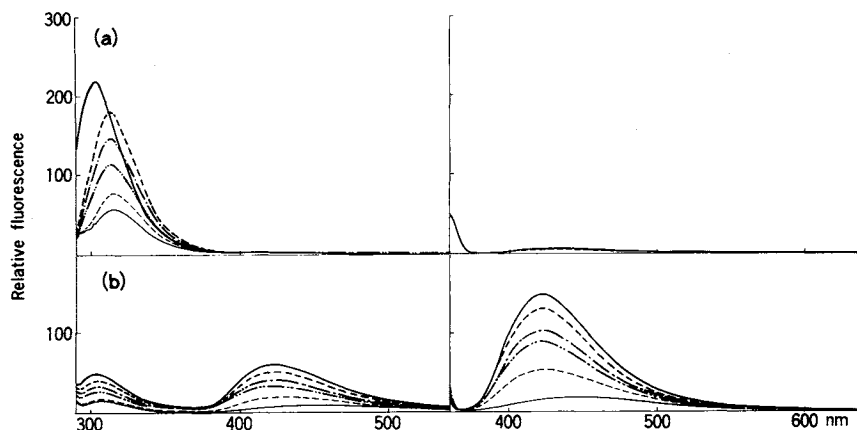

C-1027 and apoprotein (0.5 mg/ml) in 0.01 M Tris-HCl, pH 7.9, were heated by 10°C increments to 80°C.

spectra of the two proteins were significantly different. Fluorescence emission of C-1027 was observed at an excitation of both 280 and 350 nm. It had an emission maximum at 304 nm by excitation at 280 nm, which well corresponds to the absorption band of tyrosine residues in the protein moiety, and showed a second broad emission centered around 426 nm by excitation at 350 nm. While, the apoprotein showed dramatically reduced emission at 426 nm and significantly higher emission at 304 nm than C-1027 at 30°C. At 304 nm the difference in fluorescence intensity between C-1027 and apoprotein may be ascribed to fluorescence quenching related to the conformational change effected by binding of non-protein chromophore to protein moiety.

The excitation wavelengths of 280 and 350 nm were then used to examine each protein at

different temperatures ranging in 10°C intervals from 30 to 80°C . In the apoprotein spectrum, the intensity of fluorescence emission of tyrosyl residues decreased linearly as expected with increasing temperature, and the emission maximum at 304 nm shifted to 315 nm at more than 40°C after the thermal transition, whereas in C-1027, the 426 nm emission maximum from excitation at 350 nm was essentially absent at the higher temperatures. No deviation from linearity occurred with respect to the change in fluorescence emission in C-1027 and apoprotein. It would appear that such an environmental change occurred at the tyrosine residues in apoprotein, leading to a shift in the emission maximum from 304 to 315 nm. Since the emission maximum at 426 nm in C-1027 appeared to correlate with the presence of the non-protein chromophore in this protein, the fluorescence spectra suggested that chromophore might have been modified after heating, seen also in the ultraviolet absorbance spectra in which the definite absorption shoulder between 340 and 360 nm in the native C-1027 was shifted to a shorter wavelength with no definitive maximum by UV-irradiation, as reported previously²⁵. These spectral findings might point not only to modification of the non-protein chromophore but also to dissociation of the chromophore from the apoprotein of C-1027 following heating.

By using the fluorescence technique, we attempted to determine the interaction between C-1027 chr-II and apoprotein. The fluorescence of the mixture of apoprotein and chr-II was measured after the solution had been mixed well. When apoprotein was added to a phosphate buffer solution of the chromophore, the 426-nm fluorescence of the chromophore excited at 350 nm increased in relative intensity with increasing concentration of apoprotein, as shown in Fig. 11. The peak intensity increased almost 16-fold, and the emission band shifted about 20 nm in the apoprotein-nonprotein chromophore adduct formed with equimolar concentrations of the two components. The spectrum of C-1027 was much more similar to that measured for the chr-II, which occupies a largely hydrophobic environment in the holo-antibiotic. The dissociation constant (K_d) of apoprotein for chromophore, which was obtained from the fluorescence curves by the method of KONDO *et al.*, was $6.88 \times 10^{-5} \text{ M}$ under these conditions. In a study testing the interaction between apo-NCS and NCS chromophore by this technique, it was reported that apo-NCS quenched the 448-nm fluorescence of NCS-chromophore excited at 340 nm in a concentration-dependent manner and that the K_d of it was $7.0 \times 10^{-6} \text{ M}$ ²⁶. This result may indicate that the chromophore-protein interaction in NCS is more intensive than that in C-1027.

Many antitumor protein antibiotics such as NCS, MCR, AUR, AXN, and LRG are known generally to comprise an acidic protein in combination with a basic chromophore, and a similar feature holds for

Fig. 11. Change in fluorescence spectrum of C-1027 chromophore component II ($5 \times 10^{-5} \text{ M}$) in the presence of various concentrations of apoprotein.

The first spectrum was obtained at 0 M — apoprotein, followed by spectra with increasing concentration of apoprotein as follows: $0.8 \times 10^{-5} \text{ M}$ ---, $1 \times 10^{-5} \text{ M}$ ———, $1.25 \times 10^{-5} \text{ M}$ - - - - , $1.6 \times 10^{-5} \text{ M}$ ———, $2 \times 10^{-5} \text{ M}$ - - - - , $4 \times 10^{-5} \text{ M}$ - - - - and $5 \times 10^{-5} \text{ M}$ - - - - .

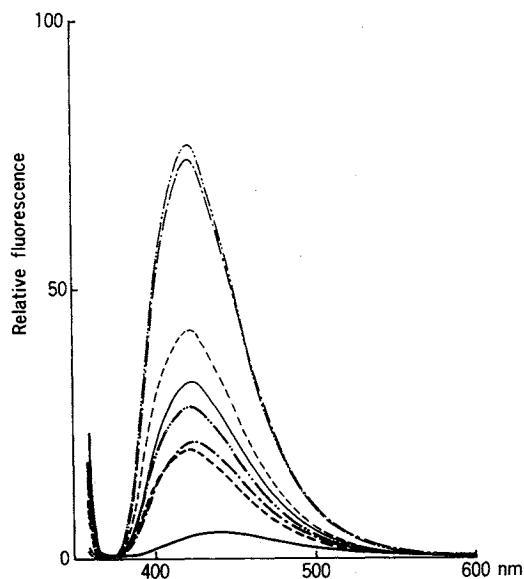

C-1027. The protein component of NCS has no cytotoxic activity and it serves primarily as a carrier protecting the chromophore from decomposition²⁷). AXN and AUR have similar functions but with different specificity regarding the nature and activity of the chromophore. In fact, despite substantial differences concerning the structure and reactivity of the antibiotic moiety, the apoproteins of NCS, MCR, AUR and AXN are similar in size, 108-113 amino acids, and have about 45% sequence similar²⁸). However, AUR-chromophore is a poor ligand for NCS-apoprotein²⁹), and MCR does not bind the NCS-chromophore well³⁰). Therefore, the overall folding of the apoprotein is expected to be similar but geometry or composition of the binding site should indicate differences that are related to the differences in the structures and activities of the chromophores. We reported earlier that holo-antibiotic C-1027 had some aminopeptidase activity when tested with 1-phenylalanyl-4-methylcoumaryl-7-amide as the substrate, and neither its chromophore alone nor its apoprotein alone had this activity⁹). Amastatin and bestatin inhibited the enzyme activity. The cytotoxicity to Ehrlich carcinoma cells *in vitro* and aminopeptidase activity of C-1027 was reduced by UV-irradiation. The chromophore has been reported to be labile to UV-irradiation^{2,5}). Degradation of the chromophore by UV-irradiation should have resulted in changes of the native conformation of C-1027 and loss of the catalytic activity. Thus, structure-activity correlation for the secondary and three-dimensional structure of the molecule should provide insight into its mode of action. However, the mode of apoprotein-chromophore interaction has not yet been clarified because the structure of apoprotein and of its chromophore has not been elucidated, except for NCS. Recently, based on detailed 2D-NMR studies and other spectral data, we found that the native chromophore obtained from isolated C-1027 consisted mainly of three structures, *i.e.*, oxazolinolate, a novel amino sugar, and a novel 9-membered endiayne core. Accordingly, we presume that chr-II, a stable C-1027 chromophore-derived reaction product, is formed by aromatization mechanism of the enediayne system of native chromophore. Therefore, the C-1027 chromophore is a member of the enediayne family of antibiotics as represented by NCS-chromophore, calicheamicins, esperamicins, and dynemicin A. This novel class of extremely potent cytotoxic natural products has been characterized as having an enediayne conjugated chromophore by EDO *et al.*³¹) and by researchers at the Lederle Laboratories^{32,33}) and Bristol-Myers^{34~37}), respectively. In addition to these, very recently, Bristol-Myers Squibb group has discovered a novel family of chromoprotein antitumor antibiotic, kedarcidin³⁸). The structure determination of kedarcidin consisting of an acidic apoprotein (114 amino acid residues) and the highly unstable chromophore possessing 9-membered ring endiayne core has been disclosed^{39, 40}).

Recently, a significant β -strand character and lack of helices have been reported for NCS from the extensive analyses of proton NMR spectra⁴¹). The globular folding of the NCS molecule was also proposed from consideration of its structural similarity with AXN⁴²). We are currently attempting conformation analysis of C-1027 and apoprotein in solution by NMR-spectroscopy, together with crystallization of C-1027 apoprotein for and preliminary X-ray diffraction analysis, to obtain detailed structural information on the whole molecule. Because of both the homology in structure and function and the variation in chromophore structure and binding site composition, this family of protein antibiotics offers a unique opportunity for studies of structure-function relationships and chromophore-protein interactions. Particularly, detailed information about the chromophore-protein interactions should lead the way toward the development of improved antitumor agents.

Acknowledgments

The author would like to thank Professor M. HORI of Showa College of Pharmaceutical Sciences for his valuable

advice and encouragement during the course of this study. The author also wishes to thank Miss K. SAKAWA in our laboratory for the preparation of this manuscript.

References

- 1) HU, J.; Y.-C. XUE, M.-Y. XIE, R. ZHANG, T. OTANI, Y. MINAMI, Y. YAMADA & T. MARUNAKA: A new macromolecular antitumor antibiotics, C-1027. I. Discovery, taxonomy of producing organism, fermentation and biological activity. *J. Antibiotics* 41: 1575~1579, 1988
- 2) OTANI, T.; Y. MINAMI, T. MARUNAKA, R. ZHANG & M.-Y. XIE: A new macromolecular antitumor antibiotic, C-1027. II. isolation and physico-chemical properties. *J. Antibiotics* 41: 1580~1585, 1988
- 3) OTANI, T.; T. YASUHARA, Y. MINAMI, T. SHIMAZU, R. ZHANG & M.-Y. XIE: Purification and primary structure of C-1027-AG, a selective antagonist of antitumor antibiotic C-1027, from *Streptomyces globisporus*. *Agric. Biol. Chem.* 55: 407~417, 1991
- 4) SAKATA, N.; S. IKENO, M. HORI, M. HAMADA & T. OTANI: Cloning and nucleotide sequencing of the antitumor antibiotic C-1027 apoprotein gene. *Biosci. Biotech. Biochem.* 56: 1592~1595, 1992
- 5) OTANI, T.; Y. MINAMI, K. SAKAWA & K. YOSHIDA: Isolation and characterization of non-protein chromophore and its degradation product from antibiotic C-1027. *J. Antibiotics* 44: 564~568, 1991
- 6) ZHEN, Y.-S.; X.-Y. MING, B. YU, T. OTANI, H. SAITO & Y. YAMADA: A new macromolecular antitumor antibiotic, C-1027. III. Antitumor activity. *J. Antibiotics* 42: 1294~1298, 1989
- 7) SUGIMOTO, Y.; T. OTANI, S. OIE, K. WIERZBA & Y. YAMADA: Mechanism of action of a new macromolecular antitumor antibiotic, C-1027. *J. Antibiotics* 43: 417~421, 1990
- 8) XU, Y.-J.; D.-D. LI & Y.-S. ZHEN: Mode of action of C-1027, a new macromolecular antitumor antibiotic with highly potent cytotoxicity, on human hepatoma BEL-7402 cells. *Cancer Chemother. Pharmacol.* 27: 41~46, 1990
- 9) SAKATA, N.; K. S.-TSUCHIYA, Y. MORIYA, H. HAYASHI, M. HORI, T. OTANI, M. NAGAI & T. AOYAGI: Aminopeptidase activity of an antitumor antibiotic, C-1027. *J. Antibiotics* 45: 113~117, 1992
- 10) ISHIDA, N.; K. MIYAZAKI, K. KUMAGAI & M. RIKIMARU: Neocarzinostatin, an antitumor antibiotic of high molecular weight. Isolation, physicochemical properties and biological activities. *J. Antibiotics, Ser. A* 18: 68~76, 1965
- 11) YAMASHITA, T.; N. NAOI, T. HIDAKA, K. WATANABE, Y. KUMADA, T. TAKEUCHI & H. UMEZAWA: Studies on auromomycin. *J. Antibiotics* 32: 330~339, 1979
- 12) CHIMURA, H.; M. ISHIZUKA, M. HAMADA, S. HORI, K. KIMURA, J. IWANAGA, T. TAKEUCHI & H. UMEZAWA: A new antibiotic, macromomycin, exhibiting antitumor and antimicrobial activity. *J. Antibiotics* 21: 44~49, 1968
- 13) YAMAGUCHI, T.; T. FURUMAI, M. SATO, T. OKUDA & N. ISHIDA: Studies on a new antitumor antibiotic, largomycin. I. Taxonomy of the largomycin-producing strain and production of the antibiotic. *J. Antibiotics* 23: 369~372, 1970
- 14) KHOKHLOV, A. S.; B. Z. CHERCHES, P. D. RESHETOV, G. M. SMIRNOVA, I. B. SOROKINA, T. A. PROKOPTZEVA, T. A. KOLODITSKAYA, V. V. SMIRNOV, S. M. NAVASHIN & I. P. FOMINA: Physico-chemical and biological studies on actinoxanthin, an antibiotic from *Actinomyces globisporus* 1131. *J. Antibiotics* 22: 541~544, 1969
- 15) KONDO, H.; H. NAKATANI & K. HIROMI: Interaction of cyclodextrins with fluorescent probes and its application to kinetic studies of amylase. *J. Biochem.* 79: 393~405, 1976
- 16) CHANG, C. T.; C.-S. C. WU & J. T. YANG: Circular dichroic analysis of protein conformation: inclusion of the β -turns. *Anal. Biochem.* 91: 13~31, 1978
- 17) MIYAZAWA, T. & E. R. BLOUT: The infrared spectra of polypeptides in various conformations: Amide I and II bands. *J. Am. Chem. Soc.* 83: 712~719, 1961
- 18) MAEDA, H.; H. SHIRAIISHI, S. ONODERA & N. ISHIDA: Conformation of antibiotic protein, neocarzinostatin, studied by plane polarized infrared spectroscopy, circular dichroism and optical rotatory dispersion. *Int. J. Pept. Protein Res.* 5: 19~26, 1973
- 19) SAMY, T. S. A.; M. ATREYI, H. HAEDA & J. MEIENHOFER: Selective tryptophan oxidation in the antitumor protein neocarzinostatin and effects on conformation and biological activity. *Biochemistry* 13: 1007~1014, 1974
- 20) MIWA, N.: Conformations of protein moieties and chromophore-protein interactions in the antitumor antibiotics, macromomycin and auromomycin, characterized by IR and CD spectral analysis. *J. Antibiotics* 35: 1553~1560, 1982
- 21) SARVER, R. W. & W. C. KRUEGER: Protein secondary structure from fourier transform infrared spectroscopy: A data base analysis. *Anal. Biochem.* 194: 89~100, 1991
- 22) CHOU, P. Y. & G. D. FASMAN: Prediction of the secondary structure of proteins from their amino acid sequence. *Adv. Enzymol.* 47: 45~48, 1978
- 23) KYTE, J. & R. F. DOOLITTLE: A simple method for displaying the hydropathic character of a protein. *J. Mol. Biol.* 157: 105~132, 1982
- 24) EDO, K.; K. SAITO, Y. AKIYAMA, M. MIZUGAKI, Y. KOIDE & N. ISHIDA: Neocarzinostatin: Carboxyl-terminal-43-

- peptide residue of apo-neocarzinostatin as the binding site of neocarzinostatin-chromophore. *Chem. Pharm. Bull.* 34: 5180~5183, 1986
- 25) OTANI, T.; Y. MINAMI, T. MARUNAKA, R. ZHANG & M.-Y. XIE: C-1027-AG, a selective antagonist of the macromolecular antitumor antibiotic, C-1027. *J. Antibiotics* 41: 1696~1698, 1988
 - 26) EDO, K.; K. SAITO, Y. AKIYAMA-MURAI, M. MIZUGAKI, Y. KOIDE & N. ISHIDA: An antitumor polypeptide antibiotic neocarzinostatin: The mode of apoprotein—chromophore interaction. *J. Antibiotics* 41: 554~562, 1988
 - 27) KAPPEN, L. S.; M. A. NAPIER & I. H. GOLDBERG: Roles of chromophore and apo-protein in neocarzinostatin action. *Proc. Natl. Acad. Sci. U.S.A.* 77: 1970~1974, 1980
 - 28) SAMY, T. S. A.; K. S. HAHM, E. J. MODEST, G. W. LAMPMAN, H. T. KEUTMANN, H. UMEZAWA, W. C. HERLIHY, B. W. GIBSON, S. A. CARR & K. BIEMANN: Primary structure of macromomycin, an antitumor antibiotic protein. *J. Biol. Chem.* 258: 183~191, 1983
 - 29) KAPPEN, L. S.; M. A. NAPIER, I. H. GOLDBERG & T. S. A. SAMY: Requirement for reducing agents in deoxyribonucleic acid strand scission by the purified chromophore of auromomycin. *Biochemistry* 19: 4780~4785, 1980
 - 30) KAPPEN, L. S. & I. H. GOLDBERG: Stabilization of neocarzinostatin nonprotein chromophore activity by interaction with apoprotein and with HeLa cells. *Biochemistry* 19: 4786~4790, 1980
 - 31) EDO, K.; M. MIZUGAKI, Y. KOIDE, H. SETO, K. FURIHATA, N. OTAKE & N. ISHIDA: The structure of neocarzinostatin chromophore possessing a novel bicyclo[7,3,0]dodecadiyne system. *Tetrahedron Lett.* 26: 331~334, 1985
 - 32) LEE, M. D.; T. S. DUNNE, M. M. SIEGEL, C. C. CHANG, G. O. MORTON & D. B. BORDERS: Calichemicins, a novel family of antitumor antibiotics. 1. Chemistry and partial structure of calichemicin γ_1^1 . *J. Am. Chem. Soc.* 109: 3464~3466, 1987
 - 33) LEE, M. D.; T. S. DUNNE, C. C. CHANG, G. A. ELLESTAD, M. M. SIEGEL, G. O. MORTON, W. J. MCGAHREN & D. B. BORDERS: Calichemicins, a novel family of antitumor antibiotics. 2. Chemistry and structure of calichemicin γ_1^1 . *J. Am. Chem. Soc.* 109: 3466~3468, 1987
 - 34) KONISHI, M.; H. OHKUMA, K. SAITOH, H. KAWAGUCHI, J. GOLIK, G. DUBAY, G. GROENEWOLD, B. KRISHNAN & T. W. DOYLE: Esperamicins, a novel class of potent antitumor antibiotics. I. Physico-chemical data and partial structure. *J. Antibiotics* 38: 1605~1609, 1985
 - 35) GOLIK, J.; J. CLARDY, G. DUBAY, G. GROENEWOLD, H. KAWAGUCHI, M. KONISHI, B. KRISHNAN, H. OHKUMA, K. SAITOH & T. W. DOYLE: Esperamicins, a novel class of potent antitumor antibiotics. 2. Structure of esperamicin X. *J. Am. Chem. Soc.* 109: 3461~3462, 1987
 - 36) GOLIK, J.; G. DUBAY, G. GROENEWOLD, H. KAWAGUCHI, M. KAWAGUCHI, M. KONISHI, B. KRISHNAN, H. OHKUMA, K. SAITOH & T. W. DOYLE: Esperamicins, a novel class of potent antitumor antibiotics. 3. Structures of esperamicins A₁, A₂, and A_{1b}. *J. Am. Chem. Soc.* 109: 3462~3464, 1987
 - 37) KONISHI, M.; H. OHKUMA, K. MATSUMOTO, T. TSUNO, H. KAMEI, T. MIYAKI, T. OKI, H. KAWAGUCHI, G. D. VANDUYNE & J. CLARDY: Dynemicin A, a novel antibiotic with the anthraquinone and 1,5-diyne-3-ene subunit. *J. Antibiotics* 42: 1449~1452, 1989
 - 38) HOFSTEAD, S. J.; J. A. MATSON, A. R. MALACKO & H. MARQUARDT: Kedarcidin, a new chromoprotein antitumor antibiotic. II. Isolation, purification and physico-chemical properties. *J. Antibiotics* 45: 1250~1254, 1992
 - 39) LEET, J. E.; D. R. SCHROEDER, S. J. HOFSTEAD, J. GOLIK, K. L. COLSON, S. HUANG, S. E. KLOHR, T. W. DOYLE & J. A. MATSON: Kedarcidin, a new chromoprotein antitumor antibiotic: Structure elucidation of kedarcidin chromophore. *J. Am. Chem. Soc.* 114: 7946~7948, 1992
 - 40) LEET, J. E.; J. GOLIK, S. J. HOFSTEAD, J. A. MATSON, A. Y. LEE & J. CLARDY: Kedarcidin chromophore: Structure elucidation of the amino sugar kedarosamine. *Tetrahedron Lett.* 33: 6107~6110, 1992
 - 41) ADJADJ, E.; J. MISPELTER, E. QUINIOU, J.-L. DIMICULI, V. FAVAUDON & J.-M. LHOSTE: Proton NMR studies of apo-neocarzinostatin from *Streptomyces carzinostaticus*. Sequence-specific assignment and secondary structure. *Eur. J. Biochem.* 190: 263~271, 1990
 - 42) PLETNEV, V. Z.; A. P. KUZIN, S. D. TRAKHANOV & P. V. KOSTETSKY: Three-dimensional structure of actinoxanthin. IV. A 2.5-Å resolution. *Biopolymers* 21: 287~300, 1982